



wPrime™ Series 280W-CI

ULTRASONIC WATER METER

Spire Metering offers the latest in Commercial/Industrial ultrasonic metering technology for reliable flow measurement. The rugged 280W-CI water meter will provide sustained flow accuracy for the life of the meter while providing connectivity to smart AMR/AMI solutions.



Applications

- Any application that requires high accuracy across all flow rates for revenue billing
- Municipal, commercial, and distribution applications including reclaim and irrigation water requirements
- Commercial buildings: malls, campus, hospitals, industrial parks, airports, facilities
- Industrial water: steel, heavy manufacturing plants, power plants, food & beverage

- Leak and tamper detection, DMA (District Metered Area) leakage detection system
- AMR/AMI projects which require flow accuracy with an economical solution

Features & Benefits

- Fully encapsulated in a heavy-duty enclosure with IP68 rating
- No moving parts; dependable ultrasonic performance without maintenance
- Unique straight-through flow sensor design, no dead cavity to attract solids or depositions
- Excellent performance at all flow rates; accuracy does not degrade over the life of the meter
- NSF-61G, OIML R49 and MID Approved
- Not affected by water impurity. Withstands the challenges in harsh environments, such as the Middle East and Africa
- Low pressure drop. Saves significant pumping cost
- Exceed ISO4064 Class D and AWWA C715
- 10 Year battery life
- Bi-directional flow; no strainer required
- Does not measure entrained air in pipe
- Unaffected by magnetic interference
- DN50 (2") to DN600 (24") sizes
- Tamper-proof design
- AMR/AMI ready with pulse, 4-20mA, M-Bus, Modbus, BACnet, wMBus, LoRaWan or 4G/Cat1 wireless
- Data Logger with 700 daily totals and 24 monthly totals
- Optional pressure sensor built into the flow sensor body

DS-280W-CI2n4-1310_Rev.10





wPrime™ Series 280W-CI ULTRASONIC WATER METER



The 280W-CI offers the most advanced water flow measurement by using state-of-the-art multi-path ultrasonic technology. It employs 2 pairs or 4 pairs of ultrasonic transducers to interrogate the flow from different positions, so that flow profile distortion has minimal impact on the measurement results. This is a significant improvement compared to single-path ultrasonic flow meters, because it is very common in real applications that there is not enough straight-pipe run after an elbow, a valve or a pump, or the sensor installation is not perfectly aligned with existing pipe line. In those scenarios, turbulence (swirl) or other type of secondary flow could cause errors with single-path flow meters.

A member of the wPrime™ Series, the 280W-CI Ultrasonic Water Meter is specially designed for commercial and industrial water metering applications where the environment is challenging and traditional mechanical water meters fail.

280W-CI is carefully engineered to offer robust performance in harsh environments. The flow sensor utilizes a crystal to generate an ultrasonic signal. There are no moving parts to wear out over time, as in traditional mechanical meters. The electronics, transducers and cables are all encapsulated in a heavy-duty metal enclosure which is IP 68 rated. It is suitable for both outdoor and indoor applications and anywhere the meter may be submersible.

The technical specification of the 280W-CI water meter meets the ISO 4064 (or OIML R49) water meter standards for Class D accuracy, and exceeds the AWWA C715 water meter standard. The operational temperature ranges from 0.1°C (32.2°F) to 60°C (140°F) including safety temperature up to 85°C. The large display can be set to display the flow total, flow rate, working time, leakage alarm, reverse flow, and more. The meter also has a remote readout which could be configured as pulse, M-Bus, RS485/Modbus, pulse, 4-20mA, BACnet, or, wireless.

Spire Metering's 280W-CI Ultrasonic Water Meter stands out among the competition due to its rugged design, wide dynamic range, robust performance and extensive AMR functions. The 280W-CI performs reliably when the water has particulate or the environment is harsh. Both commercial and industrial installations can profit from the advantages of precision, wear-free water flow measurement, operational security and long service life.





Operating Principle

The wPrime™ series ultrasonic water meter consists of a flow-cell, a pair of ultrasonic flow transducers and an integrator. The transducers are firmly mounted on the flow-cell at the optimal position. As illustrated, the transducers face each other with one on the upstream, and the other on the downstream.

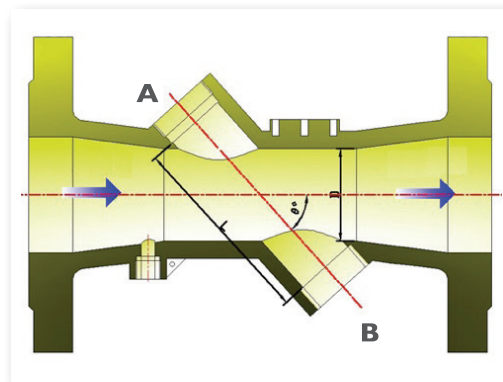

The integrator (or calculator) controls the two ultrasonic transducers to transmit and receive ultrasounds to conduct precise flow measurement. Specifically, it operates the two transducers which transmit a pulse of ultrasonic energy into the water flow toward the opposite transducer. The integrator detects the pulse signal which has traveled within the flow tube, and then is received by the opposite transducer. With advanced digital signal processing technology, the integrator precisely measures the arrival (or transit) time of each pulse signal.

Since the transit-time difference between the two pulses is directly proportional to flow velocity, it can calculate the flow velocity and flow rate. This is accomplished by combining it with the geometry of the flow-cell and fluid dynamics theory.

Only ultrasonic pulses are used to interrogate the flow which enables the meter to have no moving parts. Since the principle is based on the transit-time *difference* instead of transit-time, all the interfering factors, such as temperature, pressure, solids concentration and water quality, are cancelled out. The end result is an ultrasonic metering system which is inherently robust!

Multi-path Technology

In real application, it is not easy to install the flow sensor perfectly in line with the pipe line. A slight misalignment could cause flow profile distortion inside the flow sensor, and thus cause significant measurement errors. Spire Metering developed a unique multi-path technology to solve this problem. Two or more pairs of ultrasonic transducers are mounted on the flow sensor body to interrogate the flow from four different paths. A flow calculation algorithm based on fluid dynamics theory is then used to derive an average flow reading with improved accuracy.

One unique feature of Spire Metering's multi-path flow sensor is that all the sensing elements are in the flow instead of hiding in the pipe wall. As such, there is no cavity around the sensing elements to cause deposition or to attract solids on the sensing surfaces.

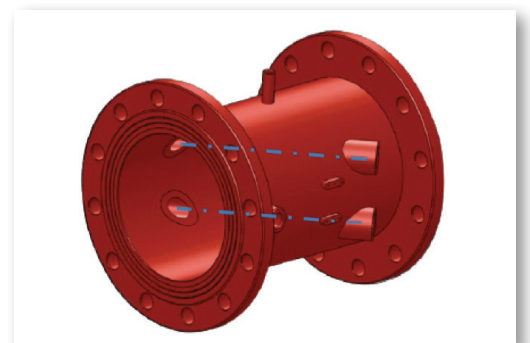



wPrime™ Series 280W-CI ULTRASONIC WATER METER

Automatic Meter Reading

The wPrime™ series water meter offers a variety of interface options, such as M-Bus, pulse, RS485/Modbus, BACnet, Pulse, 4-20mA and wireless (4G, GPRS and Radio). It is very flexible to be integrated into an AMR/AMI system.

Spire Metering also offers a complete range of AMR/AMI solutions as well as an integrated billing system. The SpireCapture system is a cutting edge fixed automatic meter reading system which integrates both wired and wireless AMR/AMI technologies. The system provides a unified platform for meter reading and data management through M-Bus networks, RF wireless networks, 4G/GPRS cellular networks as well as TCP/IP networks. In addition, it works seamlessly with Spire Metering's billing software to make data exchange fast, easy and reliable.

SpireCapture is an advanced, highly robust meter reading solution that delivers

comprehensive usage information as well as timely, high-resolution meter reading. This data enables gas, water, heat and electric utilities to eliminate on-site visits and estimated reads, reduce theft and loss, implement time-of-use billing, and profit from all of the financial and operational benefits of fixed-network AMI/AMR.

For information on AMR/AMI parts, such as concentrators, repeaters, protocol converters, data collection devices and more,

please contact : solutions@spiremt.com

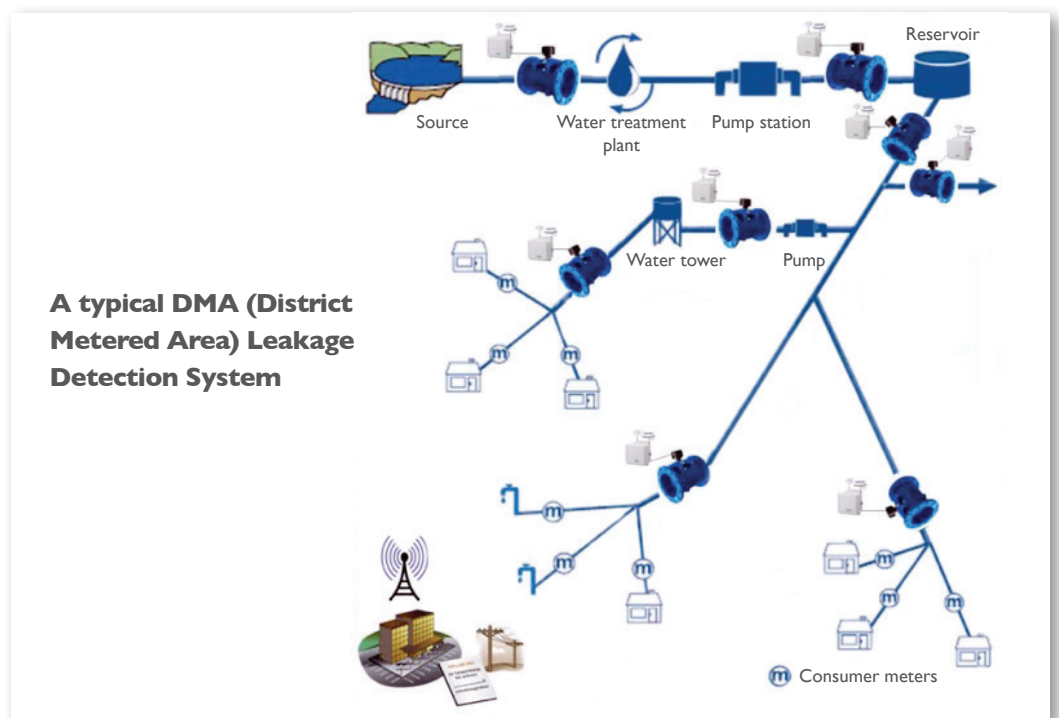



Technical Specifications

Nominal Size		DN50 2"	DN65 2 1/2"	DN80 3"	DN100 4"	DN125 5"	DN150 6"	DN200 8"	DN250 10"	DN300 12"	DN350 14"	DN400 16"	DN450 18"	DN500 20"	DN600 24"
L	mm	200	200	225	250	250	300	350	450	500	500	500	500	500	500
	inch	7.87	7.87	8.86	9.84	9.84	11.81	13.78	17.72	19.69	19.69	19.69	19.69	19.69	19.69
W	mm	165	185	200	220	250	285	340	405	460	520	580	640	715	840
	inch	6.50	7.17	7.87	8.66	9.84	11.22	13.39	15.91	18.11	20.47	22.83	25.20	28.15	33.07
H1	mm	224	229	231	235	257	260	273	327	345	394	439	499	554	674
	inch	8.82	9.02	9.09	9.25	10.12	10.24	10.75	12.87	13.58	15.51	17.28	19.65	21.81	26.54
H	mm	300	310	320	335	370	385	434	530	575	644	689	749	804	924
	inch	11.81	12.20	12.60	13.19	14.57	15.16	17.09	20.87	22.64	25.35	27.13	29.49	31.65	36.38
Weight	kg	8	8.6	10	12.5	16.4	23	31	56.5	85.6	108	125	172	195	282
	lbs	17.60	18.92	22.00	27.50	36.08	50.60	68.20	124.30	188.32	237.60	275.00	378.40	429.00	620.40
Pipe Joint		DIN Flange													
Body Material*		Cast Iron							Carbon Steel						

*Note: Stainless Steel body is available upon request.

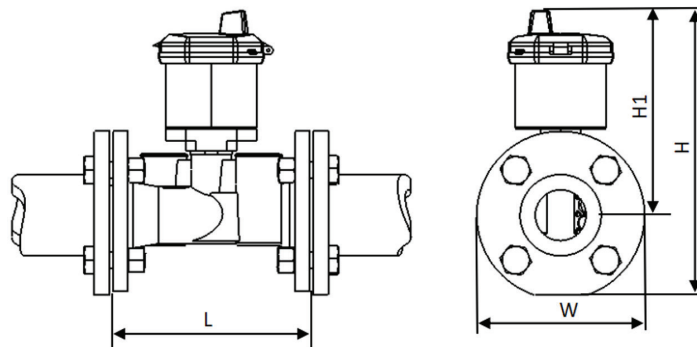

Flange Data

Nominal Size	Outer Diameter D (mm)	Number of Holes	Center Circle Diameter of the Holes D1 (mm)	Bolt Size
DN50	165	4	125	M16
DN65	185	4	145	M16
DN80	200	8	160	M16
DN100	220	8	180	M16
DN125	250	8	210	M16
DN150	285	8	240	M20
DN200	340	12	295	M20
DN250	405	12	355	M24
DN300	460	12	410	M24
DN350	520	16	470	M24
DN400	580	16	525	M27
DN450	640	20	585	M27
DN500	715	20	650	M30
DN600	840	20	770	M33

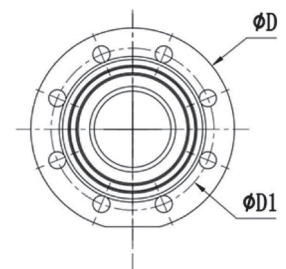

Note:

The dimension of the width and outer diameter will not affect the meter performance & life of the meter.

The shape of the flange does not affect the meter performance & life of the meter.



wPrime™ Series 280W-CI

ULTRASONIC WATER METER

R250 Flow Table

Nominal Size		DN50 2"	DN65 2 1/2"	DN80 3"	DN100 4"	DN125 5"	DN150 6"	DN200 8"	DN250 10"	DN300 12"	DN350 14"	DN400 16"	DN450 18"	DN500 20"	DN600 24"
Q4	m³/h	31.25	50	78.75	125	200	200	312.5	500	787.5	1250	2000	2000	3125	5000
	GPM	138	220	347	550	881	881	1376	2201	3467	5500	8818	8818	13779	22046
Q3	m³/h	25	40	63	100	160	160	250	400	630	1000	1600	1600	2500	4000
	GPM	110	176	277	440	704	704	1101	1761	2774	4400	7055	7055	11023	17637
Q2	m³/h	0.16	0.26	0.4	0.64	1	1	1.6	2.56	4	6.4	10.24	10.24	16	25.6
	GPM	0.7	1.1	1.8	2.8	4.5	4.5	7	11.3	17.8	28.2	45.2	45.2	70.5	112.9
Q1	m³/h	0.1	0.16	0.25	0.4	0.64	0.64	1	1.6	2.52	4	6.4	6.4	10	16
	GPM	0.4	0.7	1.1	1.8	2.8	2.8	4.4	7	11.1	17.6	28.2	28.2	44.1	70.5
Qs	m³/h	0.025	0.04	0.06	0.1	0.16	0.16	0.25	0.4	0.5	1	1.6	1.6	2.5	4
	GPM	0.11	0.18	0.27	0.44	0.7	0.7	1.1	1.76	2.2	4.4	7	7	11	18

R500 Flow Table

Nominal Size		DN50 2"	DN80 3"	DN100 4"	DN150 6"	DN200 8"	DN250 10"	DN300 12"
Q4	m³/h	31.25	78.75	125	200	312.5	500	1250
	GPM	138	347	550	1376	2201	3467	8818
Q3	m³/h	25	63	100	160	250	400	1000
	GPM	110	277	440	1101	1761	2774	7055
Q2	m³/h	0.08	0.202	0.32	0.512	0.8	1.28	3.2
	GPM	0.352	0.888	1.408	2.253	3.52	5.632	45.2
Q1	m³/h	0.05	0.126	0.2	0.32	0.5	0.8	2
	GPM	0.22	0.554	0.88	1.408	2.2	3.52	28.2
Qs	m³/h	0.025	0.06	0.1	0.25	0.4	0.5	0.5
	GPM	0.11	0.264	0.44	1.1	1.76	2.64	7

Distribuido en México por:
 Comercializadora Tecnométrica S.A. de C.V.
 Monterrey, Nuevo León, MEXICO
 TEL: (81) 1100-5755
 RFC: CTE100215AH5
 contacto@tecnometrica.com.mx
 www.tecnometrica.com.mx





wPrime™ Series 280W-CI

ULTRASONIC WATER METER

Electrical Data

Power Supply:	Battery, 3.6V, Lithium
Replacement Interval:	10 years at $t_{BAT} < 30^{\circ}C$ (86°F) based on 1 reading per day through communication module
Power Consumption:	<0.1W
Backup Power Supply:	Internal SuperCap
Communication Interface:	M-Bus, wMBus, LoRaLan, LoRaWan, pulse, 4G/Cat1 LTE, 4~20mA, Modbus, BACnet / MSTP
CE approval:	EN61326-1:2006
Electromagnetic Class:	E2

**Note: for OMS-compliant wMBus, please contact support@spiremt.com for details.*

Accuracy / MPE (Maximum Permissible Error)

MPE according to OIML R49 / ISO4064
+/-2% in range $Q2 \leq Q < Q4$; ± 5 in range $Q1 \leq Q \leq Q2$

Metrology Data

Accuracy Class:	2 (according to ISO4064 / OIML R49)
Metrological Class:	D (according to ISO4064 / OIML R49)
Range Q3/Q1:	250 (Default) ,400,500
Temperature Rating	T30, T50

Mechanical Data

Environmental Class:	B. Optional A
Electromagnetic Class:	E1
Environmental Temp:	0~55°C(32~131°F)
Permissible Flow Temp:	0.1~60°C (32.2~140°F) for permanent and up to 85°C (185°F) for short term (<24hours). However, factory calibration is done at room temperature only
Enclosure Protection:	IP68
Integrator Detachable:	No
Lid Cover Protection:	Yes
Pressure:	PN16

Pressure Loss

The pressure loss of a flow sensor is proportional to the square on the flow : $\Delta p = k \times Q^2$
 Here Δp is pressure loss, Q is volume flow rate and k is the coefficient.
 All meters have Δp less than 0.63bar at Q3, meet ISO4064 / OIML R49 standard and AWWA standard.



wPrime™ Series 280W-CI

ULTRASONIC WATER METER

Order Specifications

Base Unit

280W - CI - - - - - - -

Path*

Dual path (for DN50-200 only)	2
Quad path (for DN50-600)	4
Dual path 18	

Meter Size

Metric Unit System	English Unit System
DN50	IN2
DN65	IN2.5
DN80	IN3
DN100	IN4
DN125	IN5
DN150	IN6
DN200	IN8
DN250	IN10
DN300	IN12
DN350	IN14
DN400	IN16
DN450	IN18
DN500	IN20
DN600	IN24

Pressure Sensor

0	Without (Default)
1	With

Flange / Body Pressure

0	DIN Flange / PN16 (Default)
1	ANSI Flange / RF150# **

Dynamic Range

B	250
E	500

Sensor Body Material

1	Ductile Iron (DN50-200)
2	Carbon Steel (>DN200)

Communication Interface

0	Serial TTL (Default)
1	M-Bus
8	RS485 / Modbus
A	Dual Pulse (dry contact, requires 9~12VDC power)
9	RS485 / Modbus + 4~20mA
4	wMBus-868
5	wMBus-433
I	RF865-LoRaWan
G	4G/Cat1 Wireless

Notes:

- * The Dual Path 18 type is the meter exactly the same as shown in the OIML/MID certificate. The other two types are the same as Dual Path 18 except improved enclosure and flow cell body shape.
- ** The actual outer diameter and thickness of the water meter flange are slightly smaller than the ANSI flange standard. All other parameters of the flange comply with the ANSI standard.



Optional Components (Choose One)

Output Interface Module (Must choose Serial TTL for the Base Unit Interface)	Model No.
M-Bus Module	280AP-MB
RS485 / Modbus Module	280AP-MOD
4-20mA & RS485 / Modbus Module	280AP-MODAO
Dual Pulse Module (dry contact, require 9~12VDC power)	280AP-P2
LoRaWan Wireless Endpoint with Antenna	280AP-MR-LRW2xxx (xxx = 1:433; 2:470; 3:866; 4:868; 5:915)
4G Cellular Module with 5 Year Battery in IP67 Enclosure	Datakite-d10-4G
BACnet / MSTP Adapter	280AP-MSTP

***Note:** The standard cable length between the base unit and the interface adapter is 1.5m.

Example

280W-CI2-DN100-0-1-B-0-0 stands for the wPrime series C&I water meter for DN100 size with TTL serial output, DIN flange and Metric Unit display. Flow cell body is made from ductile iron. R250 dynamic range.

280AP-MR-LR2868 stands for a battery powered LoRa wireless endpoint operating at 868MHz free frequency band. The unit is encasolated in a mushroom antenna with a 1.5m long comminicaion cable to connect to a water meter base unit.

280W-CI2-DN50-5-1-B-0-1 stands for the wPrime series C&I water meter for DN50 size with 433MHz wMBus wireless interface, DIN flange and Metric Unit display. Flow cell body is made from ductile iron. R250 dynamic range. With built-in pressure sensor.

Distribuido en México por:

Comercializadora Tecnometrica S.A. de C.V.
Monterrey, Nuevo León, MEXICO
TEL: (81) 1100-5755
RFC: CTE100215AH5
contacto@tecnometrica.com.mx
www.tecnometrica.com.mx