

# Oxygen Detector Model XO-2200 Instruction Manual

- Thank you for purchasing XO-2200.
  - Keep this manual where it is readily accessible for quick and easy reference when necessary.
  - Thoroughly read this manual before using the equipment so that it can be used safely and correctly.
  - This package contains items as listed below. Please check carefully when unpacking. If any of the contents are missing, contact your authorized distributor or representative.
- |   |   |
|---|---|
| <input type="checkbox"/> O <sub>2</sub> detector      | 1 |
| <input type="checkbox"/> Calibration Test Certificate | 1 |
| <input type="checkbox"/> Instruction Manual           | 1 |
| <input type="checkbox"/> AAA Alkaline Battery         | 2 |
| (include battery inside the gas detector)             |   |
| <input type="checkbox"/> Safety Pin Adaptor (C-10)    | 1 |
| (include 4 screws)                                    |   |

**Note** The product battery has been used to adjust XO-2200 in our factory. We recommend replacing the battery with the attached one before using the product.

## Warranty

New Cosmos Electric Company Limited (New Cosmos) offers the following as the sole and exclusive limited warranty available to Customer. This warranty is in lieu of, and customer waives, all other warranties of any kind or nature, expressed or implied, including without limitation, any warranty for merchantability or fitness for a particular purpose. The remedies set forth herein are exclusive.

New Cosmos warrants to the original purchaser and no other person or entity (customer) that gas detection product supplied by New Cosmos shall be free from defects in materials and workmanship for a period of one (1) year from the date of purchase. This warranty does not include consumables, such as fuses, filters, etc. Certain other accessories not specifically listed here may have different warranty periods.

After examination of allegedly defective product return to New Cosmos, with freight prepaid, should the product fail to conform to this warranty, customer's only remedy and New Cosmos's only obligation shall be, at New Cosmos's sole option, replacement or repair of such non-conforming product or refund of the original purchase price of the non-conforming product. In no event will New Cosmos be liable for any other special, incidental or consequential damages or losses of any kind whatsoever, including but not limited to, loss of anticipated profits and any other loss caused by reason of non-operation of the product.

This warranty is valid only if the product is maintained and used in accordance with New Cosmos's instructions and /or recommendations. New Cosmos shall be released from all obligations under this warranty in the event repairs or modifications are made by persons other than its own or authorized service personnel or if the warranty claim results from physical abuse or misuse of the product.

## 2. Part Names and Functions

### (1) Main Body

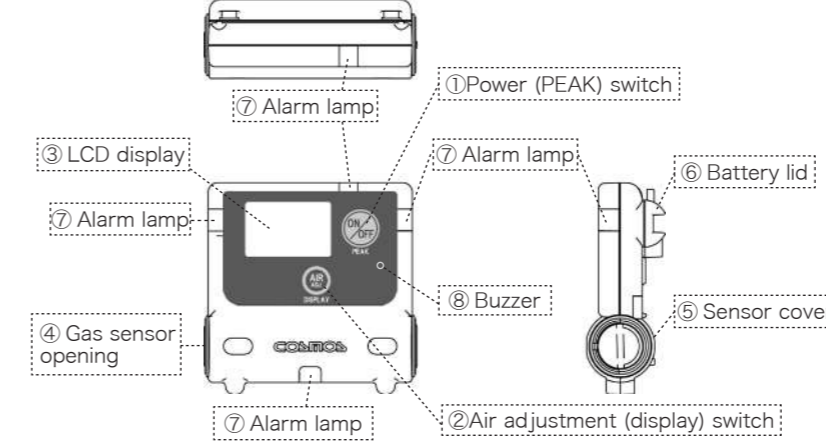

#### • Products body description

① Power (PEAK) switch	Turns the power supply ON/OFF. Or it is used for the PEAK hold function.
② Air adjustment (display) switch	Adjusts the air (21% adjustment). ("Display" function is not available.)
③ Liquid crystal display	Displays the different types of indications including gas concentration (refer to page 4).
④ Gas sensor opening	Port to detect oxygen concentration.
⑤ Sensor cover	To hold the gas sensor.
⑥ Battery lid	Lid for the battery compartment.
⑦ Alarm lamp	Blinks when the alarm is activated.
⑧ Buzzer	Sounds when an alarm is activated.

### (2) LCD Display

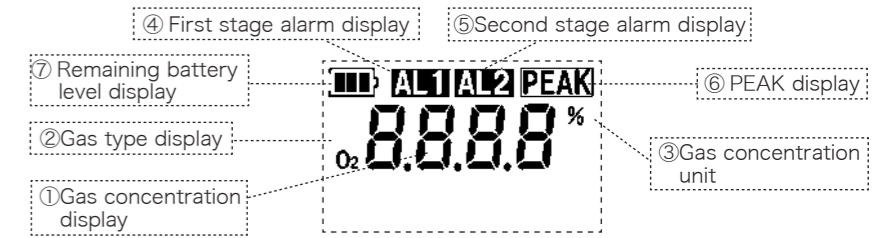

#### • LCD display description

① Gas concentration display	Digital display of gas concentration values.
② Gas type display	Displays gas types.
③ Gas concentration unit	Displays gas concentration unit.
④ First stage alarm display	Blinks when the O <sub>2</sub> concentration lowers the first stage alarm level.
⑤ Second stage alarm display	Blinks when the O <sub>2</sub> concentration lowers the second stage alarm level.
⑥ PEAK display	Displays when the gas concentration indicates the PEAK value.
⑦ Remaining battery level display	Displays remaining battery level.

## 1. Introduction

- This product is an O<sub>2</sub> detector to prevent from oxygen deficiency by alarm buzzer, lamp and vibration when the O<sub>2</sub> concentration lowers the alarm set value.

### ● Description of Symbols

In order to use the Gas Detector safely, be sure to observe the following symbols.

<b>⚠ DANGER</b>	Indicates information that, if not heeded, is likely to result in death or serious injury.
<b>⚠ WARNING</b>	Indicates information that, if not heeded, could possibly result in death or serious injury.
<b>⚠ CAUTION</b>	Indicates information that, if not heeded, could result in minor injury, or damage to the product.
<b>Note</b>	This symbol indicates advice on how to handle the product.

### ● Explosion-proof related information

**⚠ CAUTION** XO-2200 is an intrinsic safety. Use the detector as directed below.

Intrinsic safety: Exib II BT3X (Japan)  
Rating: 1.5V DC 0.18A (LR03)  
Caution:

- Replace batteries only in an area known to be NON-HAZARDOUS.
- In case of measurement of O<sub>2</sub> concentration, do not use for measurement except mixture of air and combustible gas or vapor and toxic gas.

### ● Safe Operation

In order to use the Gas Detector safely, be sure to observe the following items.

- ⚠ DANGER** : In the event of an alarm, immediately take the necessary measures to prevent oxygen deficiency.
  - Do not block the gas sensor opening.
- ⚠ DANGER** : In case liquid spill from the sensor (by mechanical shock etc.)
  - Immediately wash clothes in water when liquid is adhered.
  - In case of getting liquid in eyes or ears, immediately wash off with water and consult a doctor.
- ⚠ WARNING** : Be sure to execute daily check and periodical check.
- ⚠ CAUTION** :
  - Do not disassemble or modify the XO-2200. It may impair intrinsic safety characteristics.
  - Use the product in compliance with related laws and regulations.
  - Avoid mechanical shocks, such as dropping or impacts.
  - Do not store or leave the product in place with extremely high temperatures or humidity, or extremely low temperature or humidity.
  - A sudden change in a temperature, humidity and atmospheric pressure may impair the performance of the instrument.
  - Where the atmospheric pressure of the environment is different from standard atmospheric pressure (such as at high altitude), the oxygen sensor will not provide an accurate gas concentration because the sensor is influenced by the atmospheric pressure.
  - Keep the product away from exposure to water or condensation.
  - In case of condensation, dry the product completely and a check should be performed to verify its accuracy before use.
  - Wear the detector where audible, visible and vibration alarm can be noticed easily.
  - Use AAA alkaline batteries (LR03).

### (3) Safety pin adapter (C-10) installation procedure

Installing the safety pin adapter onto the battery lid allows wearing of the product with the safety pin. The procedures are as follows.

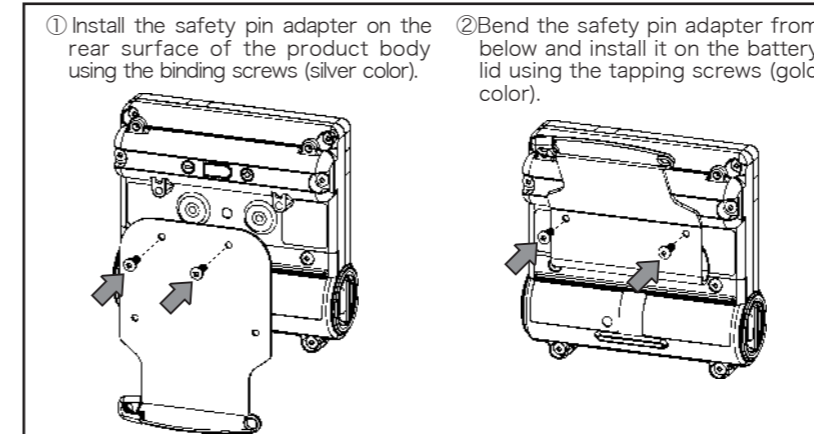

### (4) Options (Available separately)

Item name	Type	Outline
Soft case	C-11	Covers the whole device to protect it from dirt and water (Drip-proof type).
Heat-resistant soft case	C-12	Covers whole instrument to protect it from dirt and water. (Drip-proof type). The case is made of heat-resistant material to reduce temperature increases from passing high temperature. (Operating temperature range of the product remains unchanged.)
Strap with clip	ST-3	Prevents the gas detector from dropping.
Simplified inspection jig	EG-105	For simplified inspections of alarm performance and indication accuracy. (Gas used for inspection is available separately.)
Inspection gas	—	For simplified inspection.

### (5) Replacement Parts(available separately)

Item name	Type	Outline
Filter elements (containing 10 pcs)	FE-116	Filter to protect the gas sensor opening from dust and water exposure.
O <sub>2</sub> sensor element for replacement	OS-3M-D	O <sub>2</sub> sensor element for XO-2200.

## 3. Operational Procedure

### ① Turning the power supply on.

- Press and hold the [Power (PEAK)] switch for approximately 3 seconds. "on" and the count down "3→2→1" are displayed; 「the gas alarm concentration setting display」 and 「air adjustment」 are made automatically before the gas concentration is displayed.

**⚠ WARNING** Always turn on the detector in clean air. Accurate O<sub>2</sub> concentration reading cannot be obtained when the power supply is turned on in a contaminated air.

**Note** After a switch operation, the LCD display light (backlight) turns on for 5 seconds and then turns off automatically.

### ● Gas alarm concentration setting

Displays in the following order:

[1st stage alarm setting value] → [2nd stage alarm setting value]

[1st stage alarm setting value] [2nd stage alarm setting value]



#### • Gas alarm concentration setting value (Standard setting value)

Target gas	Oxygen (O <sub>2</sub> )
1st stage alarm <b>AL1</b>	19.5%
2nd stage alarm <b>AL2</b>	18.0%

● Air adjustment

Air adjustment (21% adjustment) is completed when the remaining sensor lifetime display changes from a blinking display to a steady display of "21.0".

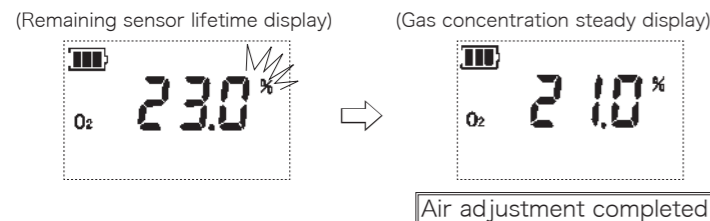

Operates gas detection after completing air adjustment.

**Note**

- Make sure that blinking "23.0%" is displayed during the air adjustment. When the sensor approaches the end of its lifetime, a value less than 23.0% is displayed during the adjustment. Replace the oxygen sensor with a new one (available separately) before the value reaches "21.0%" at the time of the adjustment. (See "Replacement Parts" on page 5)

② Gas detection (Alarm status)

**Note**

- For simultaneous alarm, the priority for alarm activation is given to Second stage alarm, then First stage alarm.
- When the O<sub>2</sub> concentration reading exceeds the service range, the service range upper limit and "OL" are displayed alternately.

● First and Second stage alarm

If the O<sub>2</sub> concentration lowers the first or second stage alarm concentration setting value, the O<sub>2</sub> concentration display, alarm display and alarm lamp blink, accompanied by alarm sound and vibration.

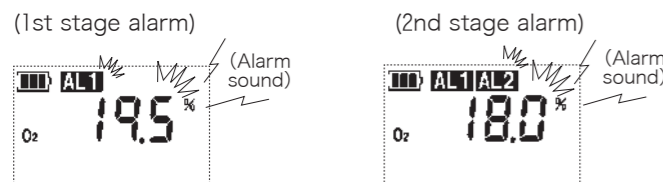

**Note**

- The cycle of the alarm sound and the alarm blinks become faster for the second stage than that for the first.
- The backlight of the LCD display turns on during an alarm.

③ Air adjustment (21% adjustment)

Press and hold the [Air Adjustment] switch for approximately 3 seconds. "Air" and count down "3→2→1" are displayed, and the air adjustment is made.

**WARNING**

- Be sure to execute the air adjustment in clean air. Accurate O<sub>2</sub> concentration reading cannot be obtained when the power supply is turned on in a contaminated air.
- Execute the air adjustment at least once a day. In addition, when the work environment (temperature or humidity) changes, make the air adjustment because the 21.0% setting may drift.

④ Peak hold function (function to hold a peak value)

Press the [Power (PEAK)] switch for a short period of time to display **PEAK**. The peak value of the gas concentration is indicated while **PEAK** remains on the display. Press the [Power (PEAK)] switch again for a short period of time to reset the peak value and return to the current value display.

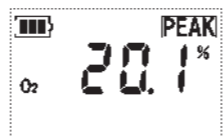

**Note**

- The standard specification of XO-2200 is the lower PEAK value.

5. Alarm Displays

Display	Content
	No remaining battery level. Replace the battery. (See "Replacing Batteries" on page 10)
	Incorrect air adjustment or sensor malfunction. Make an air adjustment again in clean air. Request repairs if the alarm does not disappear after several adjustments.
	Abnormality inside the product. Remove and reinsert the battery. Turn on the power supply to check performance. If it cannot be restored with this procedure, request repairs.
	Abnormality inside the product. Remove and reinsert the battery. Turn on the power supply to check performance. If it cannot be restored with this procedure, request repairs.

If the operation switches or displays do not operate properly other than when alarms are activated as above, remove and reinsert the battery into the product. Turn the power supply on to check performance. If it cannot be restored with this procedure, request repairs.

6. Maintenance Check

This product is a precision instrument. To ensure the accuracy of the instrument, execute maintenance check according to the following. If violation of the entries such as dropping impact, wetting or "safe operation" (refer to page 2), as well as detecting gas concentration out of measuring range, using out of operating temperature-humidity or using out of "7. Specifications" (refer to page 13), contact our dealer or agency for an inspection accompanied by a briefing.

⑤ Peak value memory function [Memorize and check the peak value between power ON and OFF.]

Press the [Power (PEAK)] switch and [Air Adjustment] switch at the same time. The display will blink only while the switches are pressed at the same time, indicating the peak value from the time of power on to the present. The subsidiary display indicates the elapsed time since the peak value was observed.

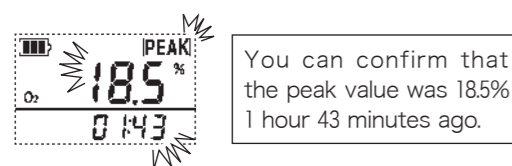

You can confirm that the peak value was 18.5% 1 hour 43 minutes ago.

**Note**

- The peak value memory function provides detailed time displays back to 99 hours 59 minutes. Beyond 100 hours, alternate displays of the **100H** and **0L** will be displayed, but with no detailed display of time. The time includes an error of ±5%.
- Even after turning off the power supply, press the [Air Adjustment] switch to display only the peak value for the period between the previous power on and off. At the next power on, the peak values return to "21.0%".

⑥ Turning the power supply off

Press and hold the [Power (PEAK)] switch for approximately 3 seconds. "oFF" and count down "3→2→1" are displayed, and the power supply turns off, accompanied by alarm sound and vibration.

4. Replacing Battery

The remaining battery level indication decreases gradually as the battery level decreases as shown below: Before remaining battery level is exhausted, the last indication will blink with an intermittent alarm sound in 10-second intervals. (Preliminary alarm) When the remaining battery level is exhausted, [Err.b] is displayed, accompanied by a continuous alarm sound. The product will no longer operate. (Final alarm) Stop the alarm sound by turning the power supply OFF.

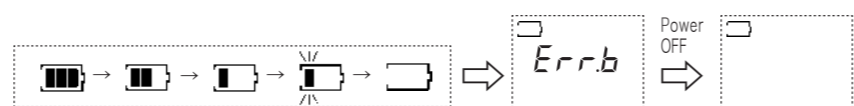

Remove the two screws shown on the right and replace the battery with a new AAA alkaline battery.

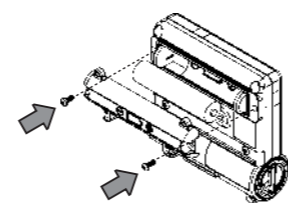

**CAUTION**

- When inserting the battery, make sure that the polarities (+ and -) are correctly positioned.
- If the battery polarity is reversed, the power supply cannot be turned on and a continuous vibration may occur depending on the type of battery. Remove the battery promptly and insert it again with the proper polarity.

7. Specifications

Model	XO-2200
Type of gas detected	Oxygen (O <sub>2</sub> )
Detection principle	Galvanic cell
Gas sampling method	Diffusion type
Measuring range (Service range)	0~25vol% (25~50vol%)
Resolution	0.1vol%
Indication accuracy <sup>(*)</sup>	Within ±0.5vol%
Alarm set value	19.5vol% (first stage), 18.0vol% (second stage)
Response time <sup>(**)</sup>	Maximum 20 seconds (90% of final reading)
Display mode	LCD (Manual backlight)
Alarm mode	Buzzer sounds, flashing red light and vibration
Functions	Remaining battery level, peak hold, memory of peak value, alarm functions except gas alarm (sensor malfunction, remaining battery level, air-adjustment malfunction), gas calibration
Explosion-proof structure	Intrinsic safety (Exib II BT3X)
Operating temperature	-10°C - 40°C, 30 -90% RH (non condensing)
Operating air pressure	Air pressure ±10%
Power	1 x AAA Alkaline dry cell (LR 03)
Battery life <sup>(***)</sup>	Approx. 5,000 hours (at 20°C with more than 20.3 Vol% of the gas concentration display)
External dimensions	W65 x D22 x H64mm (excluding protrusions)
Weight	Approx.75g (including battery)
Standard accessories	1 x AAA Alkaline dry cell, 1 x safety pin adaptor (with fixing screw)

• Specifications are subject to change for improvements without prior notice.  
 (\*1) Under identical measuring conditions. Except for the service range.  
 (\*2) Assuming 90% response and operating at 20 +/- 2°C  
 (\*3) Battery life may vary with ambient conditions, conditions of use, storage

**CAUTION**

• The sensor element is guaranteed for one year from the date of purchase. After one year, O<sub>2</sub> concentration may not be obtained properly. Consider one year of use for replacement.  
 • The above sensor guarantee is valid only if the product is maintained and used in accordance with our instructions and/or recommendations.

(1) Dairy Check

Execute dairy check before using in clean air.

① Operation

Check alarm sound, alarm lamp, vibration and LCD display are worked properly when the power supply is turned on. If not, request repairs.

② Alarm function

Check the alarm indications such as alarm sound, alarm lamp and vibration by having the instrument draw O<sub>2</sub> concentration at a level that slightly lowers the alarm level.

In the event of an abnormality in the way the O<sub>2</sub> concentration readings change, such as the alarm lamp does not flicker or the buzzer does not sound, request repairs.

③ Remaining battery level

Check the remaining battery level of the gas detector. If the remaining battery level is low, replace new battery. (See 4. "Replacing battery" on page 10)

**Note**

Alarm function and low-temperature environment hasten battery drain.

④ Gas sensor opening

Check that the gas sensor opening is closed and the filter element is stained or wet. If so, replace a new filter element. (See "Replacement Parts" on page 5)

(2) Periodical Check

To ensure the accuracy of the instrument, contact our dealer / agency for an inspection (routine check) at least once a year.

8. Glossary

- Non-hazardous area: An area where there is no possibility of an explosion from generation of a mixture of combustible gas and air under normal or abnormal conditions.
- Explosion-proof: A structure applied to electrical equipment to prevent the equipment from ignition the surrounding explosive atmosphere as the source of ignition.
- Air adjustment: The function to adjust the gas condition to "21.0%".
- Service range: The range where the concentration is indicated by gas detection but outside the indication accuracy.

**NEW COSMOS ELECTRIC CO., LTD.**

Head Office: 2-5-4 Mitsuya-naka, Yodogawa-ku, Osaka 532-0036 Japan  
 Phone. (06)6309-1505 Fax. (06)6308-8129  
 Tokyo Office: 2-6-2 Hamamatsu-cho, Minato-ku, Tokyo 105-0013 Japan  
 Phone (03)5403-2715 Fax (03)5403-2710  
 URL <http://www.new-cosmos.co.jp/en/index.html>