

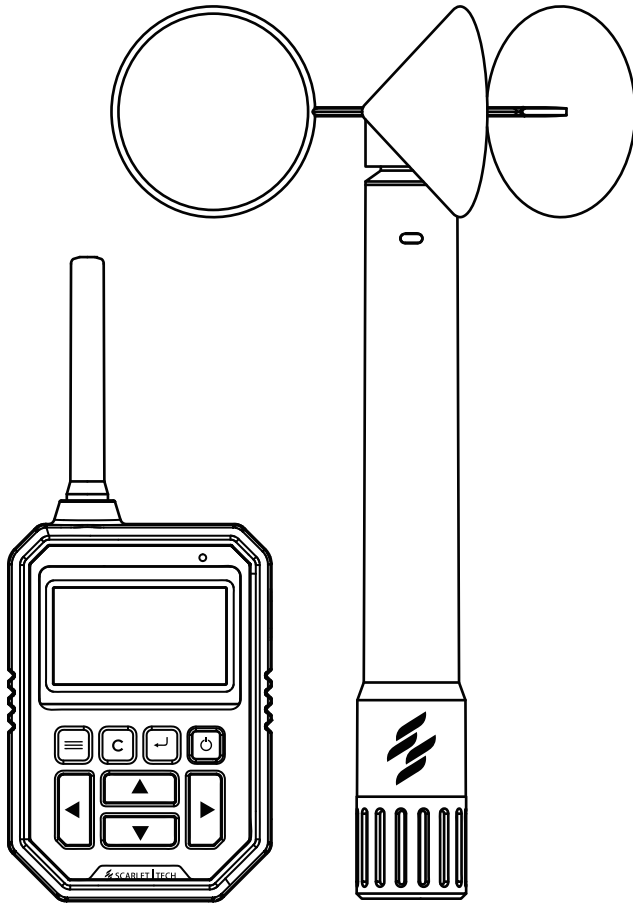

SCARLET | TECH



WR-3 Plus

Wireless Anemometer

User Guide

Page Contents

Introduction	2
Sensor & Receiver	3
Sensor	3
Wireless Connection	3
Transmission Range	3
Receiver	4
Keypad	5
Navigation Diagram	6
MAIN page	7
AVG/MAX page	8
CHART page	8
HISTORY page	9
SETTINGS Page	9
WIND SPEED settings page	10
DATA LOGGING settings page	10
GENERAL settings page	11
Functions	12
Sensors Pairing	12
Wind Speed Alarm	13
Data Logging	13
Data Export	14
Update USB driver for Windows PC	16
Power Saving Mode	17
Power off	17
Installation	18
Sensor Installation	18
Receiver Installation	18
Technical Specification	19
Wireless Sensor	19
Receiver	19
Wind Speed Sensor	20
Temperature Sensor	20
Atmospheric Pressure Sensor	20
Packing Content	21
Safety, Maintenance, & Warranty	23

Introduction

Scarlet WR-3 Plus is an industrial grade wireless anemometer for multipurpose applications and long-term environmental monitoring.

WR-3 Plus includes a wireless long-range sensor and a portable datalogger display suitable for both permanent and temporary installation.

The system measures current/average/maximum wind speed, temperature, wind chill, Beaufort scale, atmospheric pressure, and historic data graphic in high accuracy with customer selectable measurement units. Users can receive instant data and wind speed alarm at a distance up to 500-meter radius from the sensor.

WR-3 Plus further supports data logging and can export data in excel format to computers by using micro USB output.



Sensor & Receiver

■ Sensor

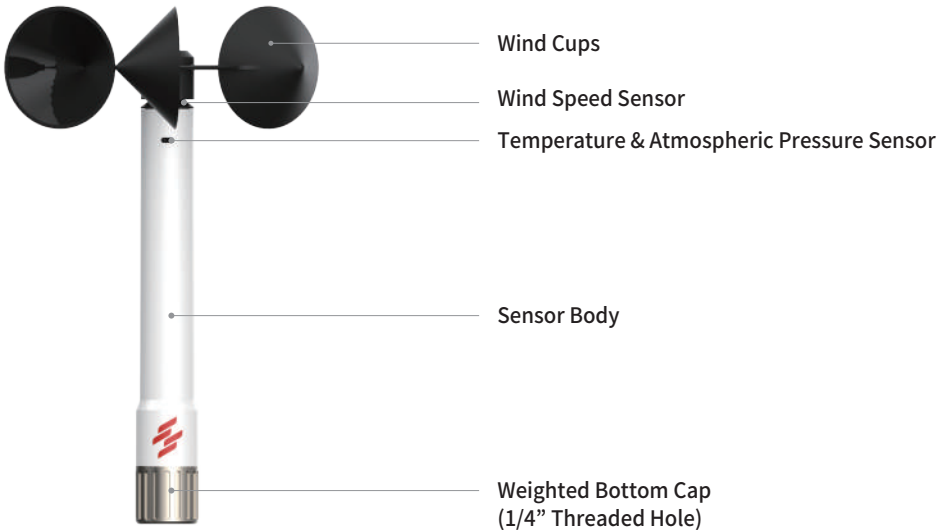

Wireless Connection

Each sensor has a unique wireless address number that has been pre-paired corresponding to the receiver display. One sensor can be connected to multiple receivers. Several anemometers can operate in close proximity without disturbance.

Transmission Range









The connection between sensor and receiver goes through Sub-1GHz wireless band (868, 915 MHz). The signal strength is shown on the receiver MAIN page. The transmission range between the sensor and the receiver can reach up to 500 meters in a direct line of sight. Inside buildings or obstacles in between may decrease the transmission range.

Receiver



Keypad



icon	Name	Functions
	Power	Power ON / OFF
	Settings	Go to Main / Settings page
	Enter	Select; Confirm
	Cancel	Cancel; Go back to the previous page
	Up	Up; Increase number; Change option
	Down	Down; Decrease number; Change option
	Left	Previous page
	Right	Next page

Navigation Diagram

After pressing the Power button, the receiver will enter the MAIN page. Users can press Right/Left and Settings /Cancel buttons to navigate through the pages.

↔ : Switching by **Right** and **Left** buttons

●—● : Switching by **Settings** and **Cancel** buttons

←—→ : Switching by **Enter** and **Cancel** buttons

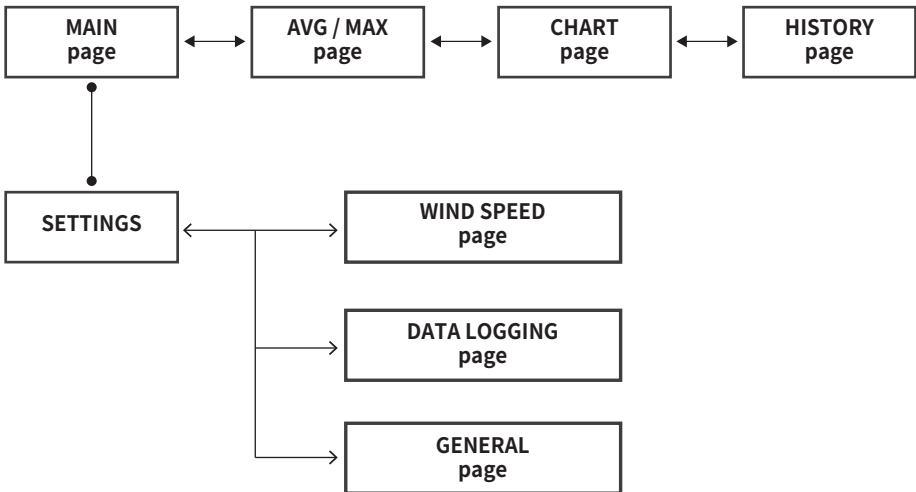

■ MAIN page

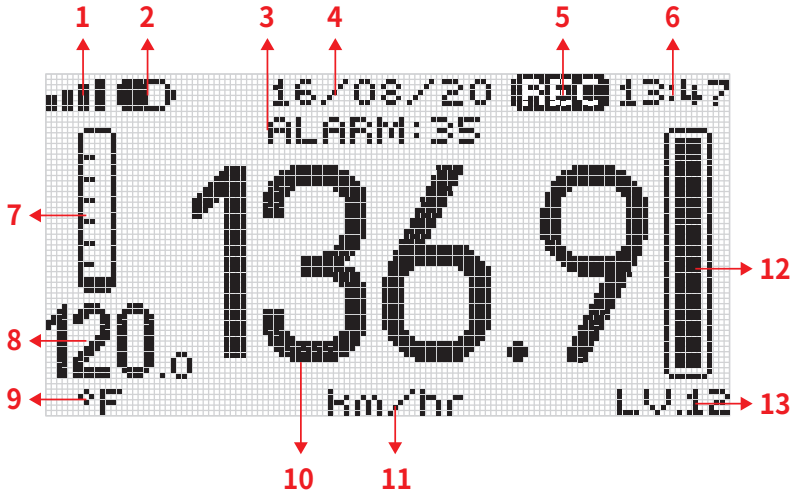

Number	Name	Definition
1	Signal Strength	The wireless signal strength between sensor and receiver
2	Receiver Power	Receiver battery level or power supply through micro USB 
3	Wind Alarm Threshold	The set wind speed alarm trigger threshold
4	Date	Current date in DD/MM/YY
5	Data Logging	Indicate the data logging function is turn ON
6	Time	Current time in HH:MM (24hr military time)
7	Thermometer	Current temperature graph (-10 to 60°C, 7 scales in total, 10°C each scale)
8	Temperature	Current temperature
9	Temperature Unit	Temperature unit: °C or °F
10	Wind Speed	Current wind speed
11	Wind Speed Unit	Set wind speed unit (m/s, km/hr, MPH, knots)
12 & 13	Beaufort Scale	Beaufort wind force scale (unit BFTS, 12 levels in total)

■ AVG/MAX page

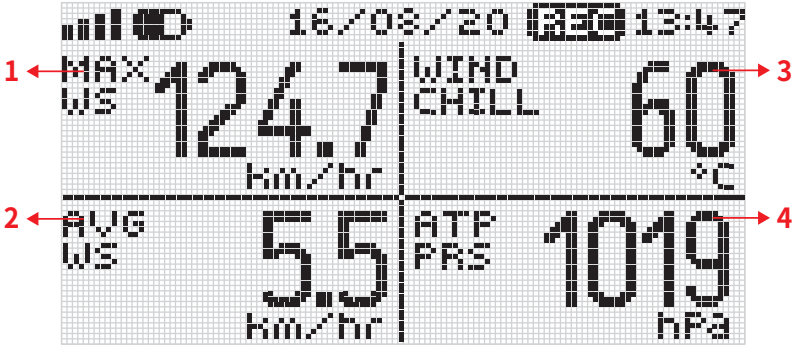

Item	Name	Definition
1	Maximum Wind Speed	Maximum wind speed for the past 12 hours since receiver turns on
2	Average Wind Speed	Average wind speed for the past 12 hours since receiver turns on
3	Wind Chill	Current wind chill index (°C)
4	Atmospheric Pressure	Current atmospheric pressure

■ CHART page

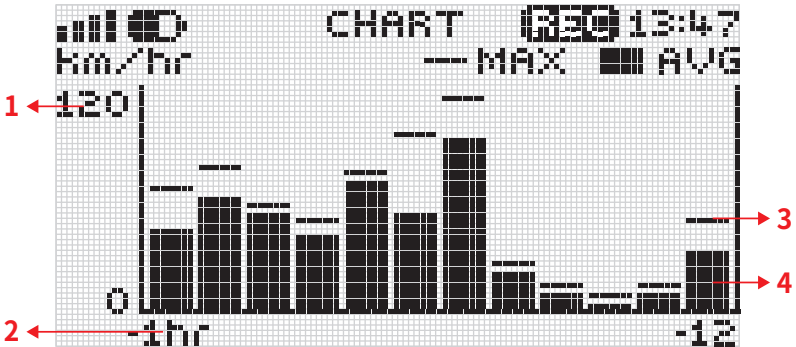

Item	Name	Definition
1	Wind Speed Value	Show wind speed value. (0 to max selectable unit)
2	Time	Show the past 12 hours from the current time (from -1 to -12, one column represents an hour)
3	Maximum Wind Speed	Maximum wind speed in the time period
4	Average Wind Speed	Average wind speed in the time period

■ HISTORY page

km/hr	AVG	MAX	TEMP °C
-01 hr	5.6	10.3	20.1
-02 hr	--	--	--
-03 hr	--	--	--
-04 hr	--	--	--
-05 hr	--	--	--

Item	Name	Definition
1	Time Period	The past 12 hours from the current time (from -1 to -12)
2	Average Wind Speed	Average wind speed of the corresponding period
3	Maximum Wind Speed	Maximum wind speed of the corresponding period
4	Average Temperature	Average temperature of the corresponding period

■ SETTINGS Page

1	WIND SPEED
2	DATA LOGGING
3	GENERAL
4	VERSION 001

Item	Name	Definition
1	Wind speed page	Wind speed and alarm setting page
2	Data logging page	Data logging setting and management page
3	General page	General setting page
4	Version	Current receiver firmware version information

■ WIND SPEED settings page



Item	Name	Definition
1	Wind Speed Unit	Wind speed measurement unit: m/s (default), km/hr, MPH, knots
2	Alarm	Wind speed alarm function: ON (default) /OFF
3	Alarm Threshold	Wind speed alarm threshold: 1 to 180 at selected unit, (default: 18)

■ DATA LOGGING settings page

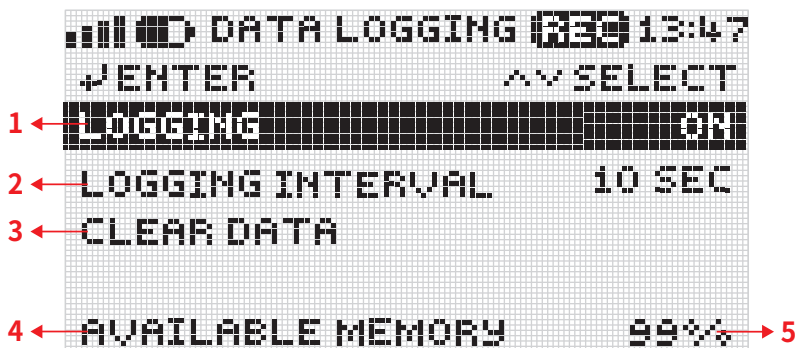

Item	Name	Definition
1	Logging	Logging function: ON / OFF(default)
2	Logging interval	Data logging interval: 2 sec, 5 sec, 10 sec (default), 1 min, 5 min, 10 min, 60 min
3	Clear data	Clear all data to release the memory
4	Available memory	Remaining data storage space in percentage

GENERAL settings page

```

    [Signal] [Battery] GENERAL [330] 13:47
    [ENTER] [SELECT]
    1 ← DATE 13/08/20
    2 ← TIME 13:47
    3 ← SENSOR ADDRESS 23
    4 ← TEMPERATURE UNIT °C
    5 ← ATMOS PRESS UNIT hPa
  
```

```

    [Signal] [Battery] GENERAL [330] 13:47
    [ENTER] [SELECT]
    6 ← DISPLAY AUTO OFF OFF
    7 ← SENSOR BATTERY 99%
  
```

Item	Name	Definition
1	Date	Set current date. DD/MM/YY
2	Time	Set current time. HH:MM (24hr military time)
3	Sensor Address	Set the wireless sensor address number that connected to this receiver
4	Temperature unit	Unit for temperature measurement. °C (default)/°F
5	Atmospheric pressure unit	Unit for atmospheric pressure measurement. hPa (default), mm Hg, bar
6	Display auto off	Display automatically switch to power saving mode after the set idle period. OFF (default), 5 min, 10 min, 30 min
7	Sensor Battery	Battery power percentage of the wireless sensor

Functions

Sensors Pairing

The wireless address number is labelled on the sensor body, as well as in the setting of each receiver.

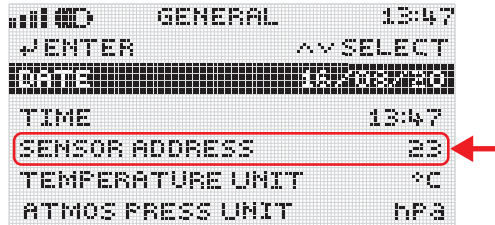
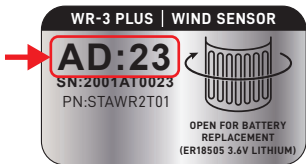

Change receiver wireless address:

1. Press Settings button go to SETTINGS page
2. Press Enter on GENERAL to go to GENERAL setting page
3. Press Up/Down to move the selection cursor to SENSOR ADDRESS, and then press Enter to modify pairing address.
4. When the address number is blinking, press Up/Down to change the number to the desired sensor address, and then press Enter to confirm.
5. When the sensor and receivers are wirelessly connected, the receiver's LED indicator will beep twice and flash GREEN light twice.

When the wireless connection between sensor and receiver is lost for over 10 minutes, the LED indicator will flash red light every 10 seconds.

Time and Measurement Units Setting

Change date, time, temperature unit, atmosphere pressure units:

1. Press Settings button go to SETTINGS page
2. Press Enter on GENERAL to go to GENERAL setting page
3. Press Up/Down and Enter to select and change the section unit

Change wind speed measurement unit:

1. Press Settings button go to SETTINGS page
2. Press Enter on WIND SPEED to go to WIND SPEED setting page
3. Press Enter on Wind SPEED UNIT
4. Press Up/Down and Enter cursor to select the unit: m/s (default), km/hr, MPH, knots

■ Wind Speed Alarm

The built-in buzzer will be triggered when the wind speed exceeds the set threshold. The display backlight flashes AMBER and LED indicator continuously blinks in RED.

Set alarm threshold:

1. Press Settings button go to SETTINGS page
2. Press Enter on WIND SPEED to go to WIND SPEED setting page
3. Press Enter on ALARM THRESHOLD
4. Press Up/Down and Enter to set the wind speed alarm threshold

Turn on alarm function:

1. Press Settings button go to SETTINGS page
2. Press Enter on WINDSPEED to go to WINDSPEED setting page
3. Press Enter on ALARM
4. Press Up/Down to select ON and press Enter to confirm the setting.

■ Data Logging

Set logging interval: (default interval: 10 seconds)

1. Press Settings button go to SETTINGS page
2. Press Up/Down and Enter to go to DATALOGGING setting page
3. Press Enter on LOGGING INTERVAL, and press Up/Down to select desired logging interval
(Supported logging interval: 2 sec, 5 sec, 10 sec, 1min, 5min, 10min, 60 min)

Logging interval can only be altered while the datalogging function is OFF.

Start Logging:

1. Go to DATA LOGGING setting page (see steps above)
2. Press Enter on LOGGING
3. Press Up/Down cursor to select ON
4. Select YES to confirm to start data logging
5.  will display on screen the top left corner to indicate the data logging function is ON

When the data logging function is ON, the receiver cannot be turn OFF.

Finish Logging:

1. Go to LOGGING setting (see steps above)
2. Press Up/Down cursor to select OFF
3. Select Yes to confirm to stop data logging
4. A logged file will be created and stored at receiver when the logging status switch from “ON” to “OFF”

There are 2 conditions which will automatically turn the data logging function OFF:

- The battery level of the receiver is under 5%.
- There is no available memory space in the receiver

For long-term data recording, Scarlet recommends to supply the receiver power through micro USB cable or make sure the battery power for receiver is sufficient for the entire logging period.

Data Export

To export the logged file from receiver, please install the Data Export Software “ScarletWind” on Windows PC.

1. Download and unzip “ScarletWind.zip” file from Scarlet’s website.
<https://scarlet-tech.com/wp-content/uploads/ScarletWind/ScarletWind.zip>
2. Connect the receiver to PC via micro USB cable.
3. A USB device will show up on the device list indicates the receiver is connected to your computer.
4. Double click to run the data export software “ScarletWind”.
5. Select COM Port of your device, and then click “Detect”.

Please turn off the Logging function before exporting log files. (See Finish Logging)

6. The indicator of COM Port will turn Green if the connection is succeeded.
7. ScarletWind will detect the connected model, click “Query” to load log file list.

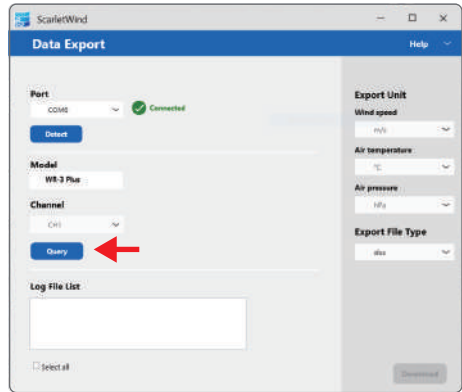
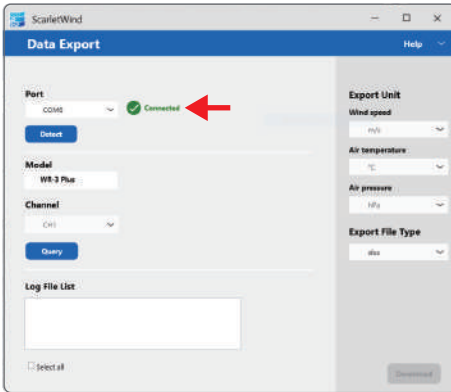

8. Select the file and file type, and click “Download”, and then select destination folder.

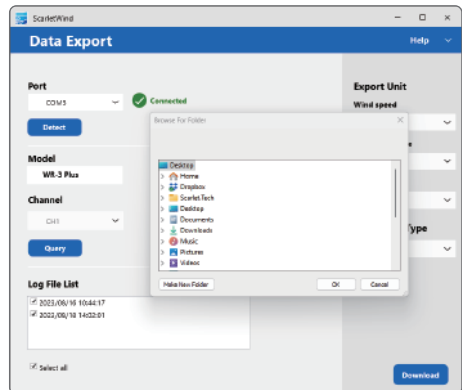
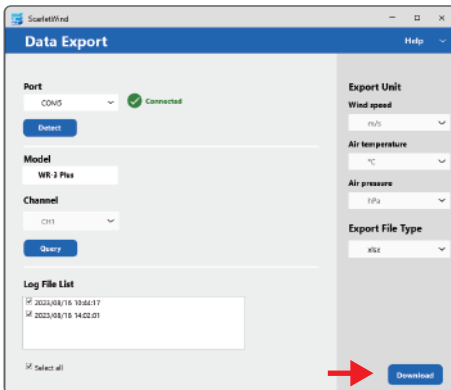

9. Click “OK” and ScarletWind will start downloading the selected logged file.
The receiver display will show “Data Downloading ...” during the downloading process.

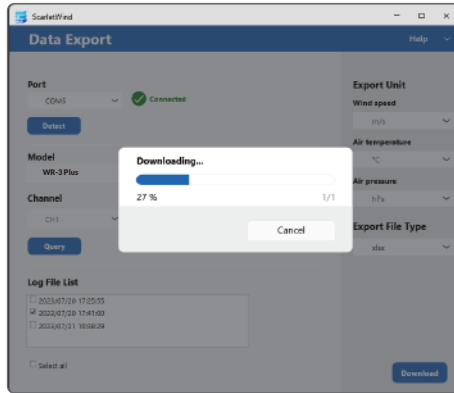
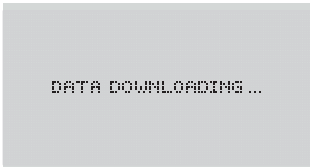

10. Wait for the “Download is completed” pop-up that indicates the data exporting is finished.
Depending on the data amount and PC performance, the time will vary from a few minutes up to several hours.

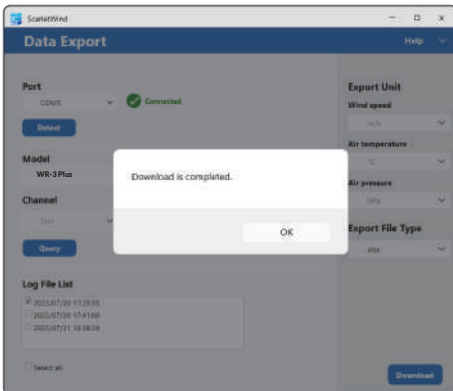

Update USB driver for Windows PC

Please update the USB driver If the USB device can't be recognized by Windows correctly.

1. Go to Device Manager.
2. Right click “Unknown USB device” (or “USB Serial Port”) with exclamation mark to update driver.

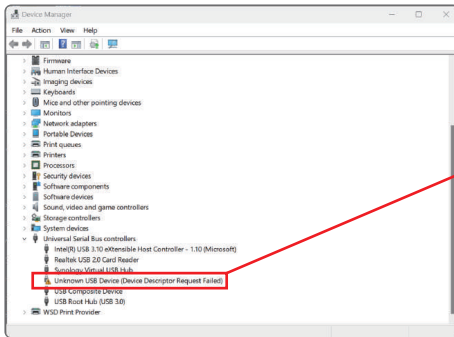

3. Select the driver “NuvotonCDC” file in the receiver USB drive to update.

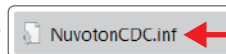
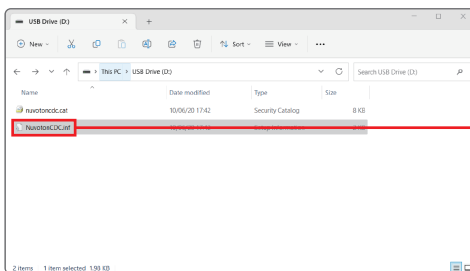
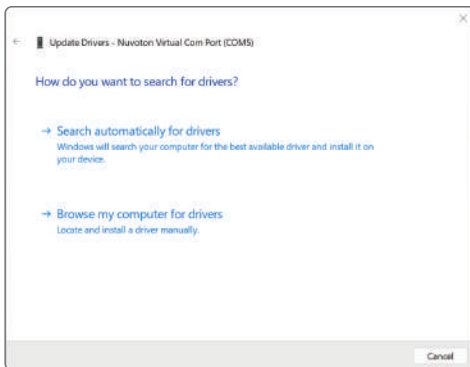

■ Power Saving Mode

In power saving mode, the receiver display will temporary turn off to reduce power consumption and the LED indicator will light GREEN every 10 seconds. All function remains working, includes alert and logging. While the wind speed alarm function is ON, the buzzer will be triggered while wind speed exceeds the set threshold.

Enable power saving mode:

1. Press Settings button go to SETTINGS page
2. Press Enter on GENERAL and Down to go to the 2nd page of GENERAL setting
3. Press Enter to select DISPLAY AUTO OFF
4. Press Up/Down cursor to set the idle period: 5min, 10min, 30min

The receiver display will automatically turn off after the set idle period to save battery power. The display will resume when any key is pressed.

■ Power Off

Power off the Reciever:

1. Press Settings button go to MAIN page
2. Long press the power button for 5 seconds

When the data logging function is ON, the Receiver cannot be powered-off by pressing power button directly.

Installation

WR-3 Plus's magnetic installation accessories support fast and flexible installation and do not require any welding or wiring on the equipment. The system setup takes place automatically upon booting up.

Sensor Installation

WR-3 Plus's sensor bottom cap has a 1/4" threaded hole for installation.

You can use Scarlet's **Magnetic Sensor Mounting Bracket** to attach the sensor to any iron/steel surface and to keep it perpendicular to the ground.

1. Loosen the clamp
2. Insert the sensor body from the bottom of the clamp
3. Tighten the clamp
4. Apply wind cups on wind sensor bearing
5. Make sure you hear a "CLICK" sound that indicates all parts are locked in place.
6. Attach the bracket on the desired magnetic surface

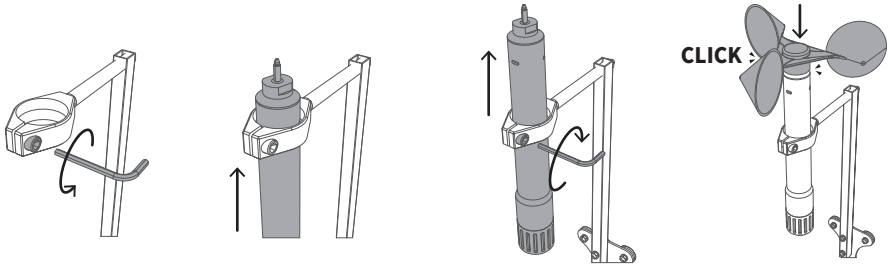

Receiver Installation

WR-3 Plus's Receiver Holder Kit comes with an adjustable holder with neodymium magnets on both ends and three pieces of metal flakes with adhesive for magnetic mount.

Apply the receiver holder:

1. Peel off the backing paper of the metal flake to reveal the adhesive side
2. Press and stick the adhesive side of the metal flake to the receiver's back cover
3. Attach the receiver to the display holder magnetically

You can attach the receiver holder on any magnetic surface or adhere the metal flake on the non-magnetic surface first before attaching the magnetic display holder.

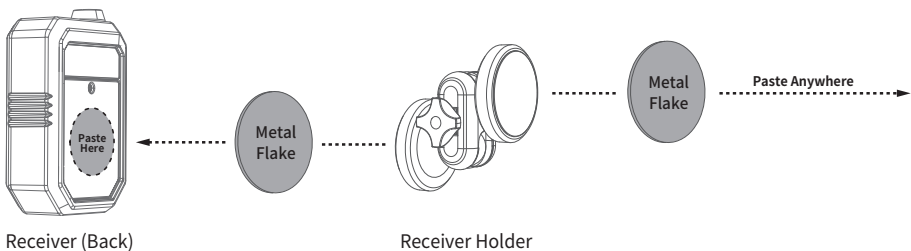

Technical Specifications

Wireless Sensor

Item	Definition
Frequency	868MHz, 915MHz
Distance	Max 500m* (depends on the applied environment)
Data Rate	Every 2 seconds
Power Supply	3.6V 18505 Lithium battery x1
Waterproof Rating	IP67
Weight	360g
Dimension	262.5 x 183.5 x 32mm

Receiver

Item	Definition
Receiver Buzzer	> 80dB
Built-in Memory	64MB
Output	.xlsx, .xls, .csv, .txt (Unicode)
Data Logger	Current wind speed Average wind speed Maximum wind speed Current temperature Current atmospheric pressure
Logging Interval	2 seconds, 5 seconds, 10 seconds (default), 1 minute, 5 minutes, 10 minutes, 60 minutes
Power Supply	1.5V AA battery x3 Micro USB port
Dimension	189.6 x 75.6 x 36.3mm
Weight	290g

Wind Speed Sensor

Item	Definition
Measurement Unit	m/s (default) knots MPH km/hr
Measurement Range	0.3...50 m/s
Measurement Resolution	0.1 m/s 0.1 knots 0.1 MPH 0.1 km/hr
Measurement Accuracy	±2% FS

Temperature Sensor

Item	Definition
Measurement Unit	°C (default) °F
Measurement Range	-30°C...60°C
Measurement Resolution	0.1°C 0.1°F
Measurement Accuracy	±1°C

Atmospheric Pressure Sensor

Item	Definition
Measurement Unit	hPa (default) mmHg bar
Measurement Range	500...1100 hPa
Measurement Resolution	1 hPa 0.1 mmHg 0.001 bar
Measurement Accuracy	±4 hPa

Package Content

- Wireless Sensor
- Wind Cups
- Receiver
- Receiver Antenna
- Receiver Holder
- Adhesive Metal Flakes x 3 (holder kit for Receiver Holder installation)
- AA Battery x 3 (for Receiver)
- 3.6V 18505 Lithium battery x1 (placed in Sensor)
- User Manual & Certificate



Wireless Sensor



Wind Cups



Receiver



Receiver Antenna



Receiver Holder & holder kit



AA Battery x 3
(for Receiver)



3.6V 18505
Lithium battery x1
(placed in Sensor)

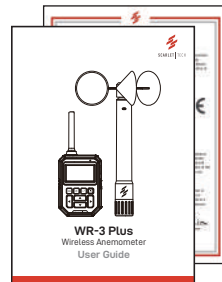

User Manual & Certificate

Optional Accessories

- Magnetic Sensor Mounting Bracket
- Spare Wind Cups
- Spare Sensor Battery (3.6V 18505 Lithium battery)
- External Antenna



Magnetic Sensor
Mounting Bracket



Wind Cups



3.6V 18505 Lithium battery

Safety, Maintenance, & Warranty

Operating Environment

The operating temperature of the anemometer system is designed to work in an ambient temperature between 5°C to 60°C (40°F to 140°F) at 20~80%RH. The storage temperature is between -20°C to 60°C (-4°F to 140°F). The instrument can be damaged if stored and operated outside of these temperature ranges. Avoid exposing the instrument to extreme changes of weather and or temperature in a continuous short period of time.

Sensor Battery Replacement

The wireless sensor is powered by a 3.6V 18505 Lithium battery. Its battery level is displayed on the 2nd page of the GENERAL setting.

- Turn the battery cap counter clockwise to remove it.
- Take out the battery container from the sensor.
- Replace the battery with a new 3.6V 18505 Lithium battery.

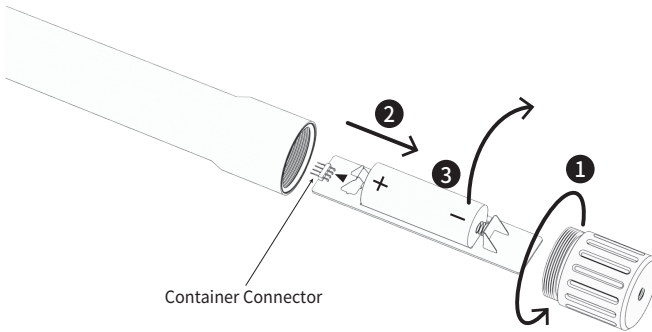

- Put back the battery container into the sensor (Please note the placement direction).

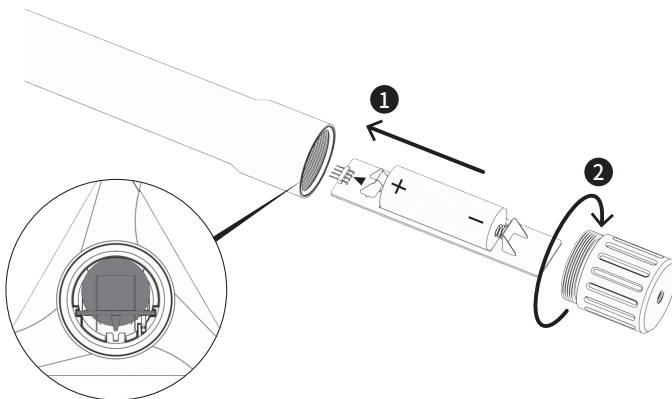

- Make sure the O-ring is correctly aligned to the battery cap for waterproof protection.
- Put back the battery cap in clockwise direction to finish the battery changing.



Receiver Battery Replacement

The receiver is powered by 3 AA 1.5V batteries. The battery level is displayed on the top of the display.

- Remove the screw and then remove the battery cover on the back.
- Replace the batteries with 3 new 1.5V AA batteries.
- Place back the battery cover and fasten the screw.



Warranty Conditions

This instrument is guaranteed for a one-year limited warranty against material or production defects, in accordance with our general sales conditions. During the warranty period, Scarlet Tech reserves the right to decide either to repair or replace the product.

Should you need any reason to return the instrument for repair or replacement, take prior agreements with the local distributor from whom you bought it. Please use the original packaging for return. Do not forget to enclose a report describing the reasons for returning (detected fault). Any damage that occurred in transit due to non-original packaging will be charged to the customer.

Scarlet Tech's One-year Limited Warranty does NOT apply to:

- Accessories and batteries (not covered by warranty)
- Repairs made necessary by improper use or improper combination with incompatible accessories or equipment.
- Repairs made necessary by improper shipping material causing damages in transit.
- Repairs made necessary by previous attempts for the repair carried out by non-skilled or unauthorized personnel.
- Instruments for whatever reason modified by the customer himself without the explicit authorization of our Technical Dept.

The contents of this manual may not be reproduced in any form whatsoever without the authorization from Scarlet Tech.

Federal Communication Commission Interference Statement

This equipment has been tested and found to comply with the limits for a Class B digital device, pursuant to Part 15 of the FCC Rules. These limits are designed to provide reasonable protection against harmful interference in a residential installation.

This equipment generates, uses and can radiate radio frequency energy and, if not installed and used in accordance with the instructions, may cause harmful interference to radio communications. However, there is no guarantee that interference will not occur in a particular installation. If this equipment does cause harmful interference to radio or television reception, which can be determined by turning the equipment off and on, the user is encouraged to try to correct the interference by one of the following measures:

- Reorient or relocate the receiving antenna.
- Increase the separation between the equipment and receiver.
- Connect the equipment into an outlet on a circuit different from that to which the receiver is connected.
- Consult the dealer or an experienced radio/TV technician for help.

FCC Caution: To assure continued compliance, any changes or modifications not expressly approved by the party responsible for compliance could void the user's authority to operate this equipment. (Example - use only shielded interface cables when connecting to computer or peripheral devices).

FCC Radiation Exposure Statement

This equipment complies with FCC RF radiation exposure limits set forth for an uncontrolled environment. This equipment should be installed and operated with a minimum distance of 20 centimeters between the radiator and your body.

This transmitter must not be co-located or operating in conjunction with any other antenna or transmitter.

The antennas used for this transmitter must be installed to provide a separation distance of at least 20 cm from all persons and must not be co-located or operating in conjunction with any other antenna or transmitter.

This device complies with Part 15 of the FCC Rules. Operation is subject to the following two conditions:

(1) This device may not cause harmful interference, and (2) This device must accept any interference received, including interference that may cause undesired operation.



Scarlet Tech Co., Ltd.
© 2021 Scarlet Tech Co., Ltd. All rights reserved.
4F-3, No. 347, HePing E Rd, 2nd Sec, DaAn District, Taipei City 106, Taiwan
info@scarlet.com.tw
www.scarlet-tech.com

version 231003.1